

ZCT 104

MODERN PHYSICS

ACADEMIC SESSION 2005/06  
(SECOND SEMESTER)

TUTORIAL PROBLEM  
SETS

## TUTORIAL 1 SPECIAL RELATIVITY

*(BASED ON UNDERSTANDING PHYSICS, CUMMINGS et al, John Wiley and Sons)*

### SEC. 38-2 ORIGINS OF SPECIAL RELATIVITY

#### 1. Chasing Light.

What fraction of the speed of light does each of the following speeds  $v$  represent? That is, what is the value of the ratio  $v/c$ ? (a) A typical rate of continental drift, 3 cm/y. (b) A high way speed limit of 100 km/h. (c) A supersonic plane flying at Mach 2.5 = 3100 km/h. (d) The Earth in orbit around the Sun at 30 km/s. (e) What conclusion(s) do you draw about the need for special relativity to describe and analyze most everyday phenomena? (Note: Some everyday phenomena can be derived from relativity. For example, magnetism can be described as arising from electrostatics plus special relativity applied to the slow-moving charges in wires.) ( $v/c = 3.16 \times 10^{-18}$ .;  $v/c = 9.26 \times 10^{-8}$ .;  $v/c = 2.87 \times 10^{-6}$ .;  $v/c = 10^{-4}$ .)

### SEC. 38-3 . THE PRINCIPLE OF RELATIVITY

#### 3. Examples of the Principles of Relativity

Identical experiments are carried out (1) in a high-speed train moving at constant speed along a horizontal track with the shades drawn and (2) in a closed freight container on the platform as the train passes. Copy the following list and mark with a "yes" quantities that will necessarily be the same as measured in the two frames. Mark with a "no" quantities that are not necessarily the same as measured in the two frames. (a) The time it takes for light to travel one meter in a vacuum; (b) the kinetic energy of an electron accelerated from rest through a voltage difference of one million volts; (c) the time for half the number of radioactive particles at rest to decay; (d) the mass of a proton; (e) the structure of DNA for an amoeba; (f) Newton's Second Law of Motion:  $F = ma$ ; (g) the value of the downward acceleration of gravity  $g$ .

### SEC. 38-4. LOCATING EVENTS WITH AN INTELLIGENT OBSERVER

#### 6. Eruption from the Sun

You see a sudden eruption on the surface of the Sun. From solar theory you predict that the eruption emitted a pulse of particles that is moving toward the Earth at one-eighth the speed of light. How long do you have to seek shelter from the radiation that will be emitted when the particle pulse hits the Earth? Take the light-travel time from the Sun to the Earth to be 8 minutes. (56 minutes)

### SEC. 38-5 LABORATORY AND ROCKET LATTICEWORKS OF CLOCKS

#### 7. Synchronizing a Clock

In a vast latticework of meter sticks and clocks, you stand next to a lattice clock whose coordinates are  $x = 8$  km,  $y = 40$  km,  $z = 44$  km. When you receive the synchronizing flash, to what time do you quickly set your clock? ( $2 \times 10^{-4}$  second)

#### 10. Where and When?

Two firecrackers explode at the same place in the laboratory and are separated by a time of 12 years. (a) What is the spatial distance between these two events in a rocket in which the events are separated in time by 13 years? (b) What is the relative speed of the rocket and laboratory frames? Express your answer as a fraction of the speed of light. ( $4.7 \times 10^{16}$  meters.; a little more than one-third the speed of light)

#### 13. Fast-Moving Muons

The half-life of stationary muons is measured to be 1.6 microseconds. Half of any initial number of stationary muons decays in one half-life. Cosmic rays colliding with atoms in the upper atmosphere of the Earth create muons, some of which move downward toward the Earth's surface. The mean lifetime of high-speed muons in one such burst is measured to be 16 microseconds. (a) Find the speed of these muons relative to the Earth. (b) Moving at this speed, how far will the muons move in one half-life? (c) How far would this pulse move in one half-life if there were no relativistic time stretching? (d) In the relativistic case, how far will the pulse move in 10 half-lives? (e) An initial pulse consisting of  $10^8$  muons is created at a distance above the Earth's surface given in part (d). How many will remain at the Earth's surface? Assume that the pulse moves vertically downward and none are lost to collisions. (Ninety-nine percent of the Earth's atmosphere lies below 40 km altitude.)

$$\left(\frac{v}{c} = 0.995.; 4.8 \times 10^3 \text{ meters.}; 480 \text{ meters}; 48 \text{ kilometers.}; 9.8 \times 10^4\right)$$

### 15. Living a Thousand Years in One Year

Living a Thousand Years in One Year. You wish to make a round trip from Earth in a spaceship, traveling at constant speed in a straight line for 6 months on your watch and then returning at the same constant speed. You wish, further, to find Earth to be 1000 years older on your return. (a) What is the value of your constant speed with respect to Earth? (b) How much do you age during the trip? (c) Does it matter whether or not you travel in a straight line? For example, could you travel in a huge circle that loops back to Earth? ( $v/c = 0.9999995.$  ; one year)

## SEC 38-8 . CAUSE AND EFFECT

### 17. Relations between Events

The table shows the  $t$  and  $x$  coordinates of three events as observed in the laboratory frame.

Laboratory Coordinates of Three Events

Event	$t$ years	$x$ light- years
<b>Event 1</b>	<b>2</b>	<b>1</b>
<b>Event 2</b>	<b>7</b>	<b>4</b>
<b>Event 3</b>	<b>5</b>	<b>6</b>

On a piece of paper list vertically every pair of these events: (1,2), (1, 3), (2, 3). (a) Next to each pair write “time-like,” “light-like,” 0 “space-like” for the relationship between those two events. (b) Next to each pair, write “Yes” if it is possible for one of the events to cause the other event and “No” if a cause and effect relation between them is not possible. (For full benefit of this exercise construct and analyze your own tables.)

**ANS: (1,2) timelike yes; (1,3) spacelike no; (2,3) lightlike yes**

### 22. Proton Crosses Galaxy

Find the energy of a proton that crosses our galaxy (diameter 100 000 light-years) in one minute of its own time. ( $5.27 \times 10^{10} mc^2$ )

## 38-10 MOMENTUM AND ENERGY

### 23. Converting Mass to Energy

The values of the masses in the reaction  $p + {}^{19}\text{F} \rightarrow \alpha + {}^{16}\text{O}$  have been determined by a mass spectrometer to have the values:  $m(p) = 1.00782$ ,  $m(F) = 18.998405u$ ,  $m(\alpha) = 4.002603u$ ,  $m(O) = 15.994915u$ . Here  $u$  is the atomic mass unit (Section 1.7). How much energy is released in this reaction? Express your answer in both kilograms and MeV. ( $1.4467 \times 10^{-29}$  kilogram ;  $1.3020 \times 10^{-12}$  joules )

### 27. Powerful Proton

A proton exits an accelerator with a kinetic energy equal to  $N$  times its rest energy. Find expressions for its (a) speed and (b) momentum. ( $\frac{[N(N+2)]^{1/2}}{N+1}c.$  ;  $p = [N(N+2)]^{1/2} mc.$ )

### 30. A Box of Light

Estimate the power in kilowatts used to light a city of 8 million inhabitants. If all this light generated during one hour in the evening could be captured and put in a box, how much would the mass of the box increase? (16 million kilowatts; 0.64 g)

**SEC. 38-11 . THE LORENTZ TRANSFORMATION****32. Really Simultaneous?**

(a) Two events occur at the same time in the laboratory frame and at the laboratory coordinates  $(x_1 = 10 \text{ km}, y_1 = 4 \text{ km}, z_1 = 6 \text{ km})$  and  $(x_2 = 10 \text{ km}, y_2 = 7 \text{ km}, z_2 = -10 \text{ km})$ . Will these two events be simultaneous in a rocket frame moving with speed  $v = 0.8c$  in the  $x$  direction in the laboratory frame? Explain your answer. (b) Three events occur at the same time in the laboratory frame and at the laboratory coordinates  $(x_0, y_1, z_1)$ ,  $(x_0, y_2, z_2)$  and  $(x_0, y_3, z_3)$  where  $x_0$  has the same value for all three events. Will these three events be simultaneous in a rocket frame moving with speed  $v$  in the laboratory  $x$  direction? Explain your answer. (c) Use your results of parts (a) and (b) to make a general statement about simultaneity of events in laboratory and rocket frames.

**ANS:** (a) simultaneous—in the rocket frame ( $\Delta t' = 0$ ); (b) events are *simultaneous* in both the laboratory and rocket frames for the pair of events in part (a) and for all three pair of events in part (b);

**38-12 LORENTZ CONTRACTION****36. Electron Shrinks Distance**

An evacuated tube at rest in the laboratory has a length 3.00 m as measured in the laboratory. An electron moves at speed  $v = 0.999\,987c$  in the laboratory along the axis of this evacuated tube. What is the length of the tube measured in the rest frame of the electron? (1.53 cm)

**39. Traveling to the Galactic Center**

(a) Can a person, in principle, travel from Earth to the center of our galaxy, which is 23 000 ly distant, in one lifetime? Explain using either length contraction or time dilation arguments. (b) What constant speed with respect to the galaxy is required to make the trip in 30 y of the traveler's life time? (Yes;  $v/c = 0.999\,999\,15$ )

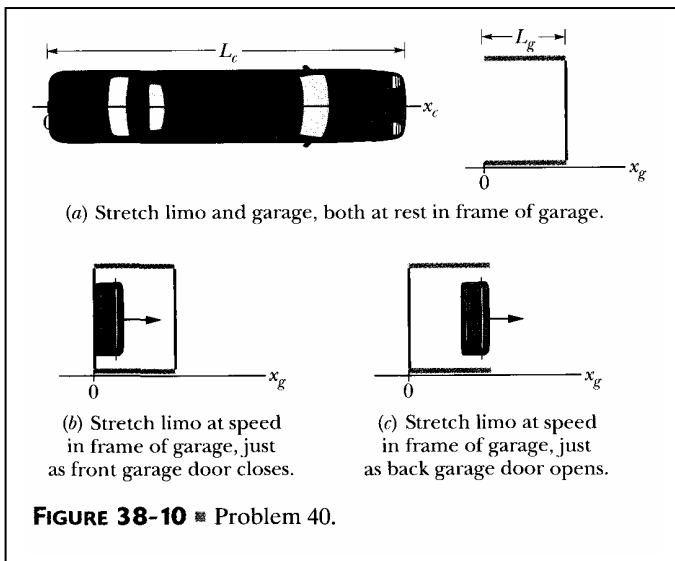
**40. Limo in the Garage**

**FIGURE 38-10** ■ Problem 40.

Carman has just purchased the world's longest stretch limo, which has proper length  $L = 30.0 \text{ m}$ . Part (a) of Figure 38-10 shows the limo parked at rest in front of a garage of proper length  $L_g = 6.00 \text{ m}$ , which has front and back doors. Looking at the limo parked in front of the garage, Carman says there is no way that the limo can fit into the garage. “*Au con traire!*” shouts Garageman, “Under the right circumstances the limo can fit into the garage with both garage doors closed and room to spare!” Garageman envisions a fast-moving limo that takes up exactly one-third of the proper length of the garage. Part (b) of Figure 38-10 shows the speeding limo just as the front garage door closes behind it as recorded in the garage frame. Part (c) of Figure 38-10 shows the limo just as the back garage door opens in front of it as recorded in the garage frame. Find the speed of the

limo with respect to the garage required for this scenario to take place. ( $v = 0.99778c$ .)

**SEC 38-13 RELATIVITY OF VELOCITIES****42. Separating Galaxies.**

Galaxy A is measured to be receding from us on Earth with a speed of  $0.3c$ . Galaxy B, located in precisely the opposite direction, is also receding from us at the same speed. What recessional velocity will an observer on galaxy A measure (a) for our galaxy, and (b) for galaxy B? ( $0.3c$ .,  $-0/55c$ )

**44. Transit Time**

An unpowered spaceship whose rest length 350 meters has a speed  $0.82c$  with respect to Earth. A micrometeorite, also with speed of  $0.82c$  with respect to Earth, passes spaceship on an antiparallel track that is moving in the opposite direction. How long does it take the micrometeorite to pass spaceship as measured on the ship? ( $1.2 \times 10^{-6}$  second.)



## TUTORIAL 2

## Black Body, Photoelectricity, Compton Scattering, X-rays, Pair-production/annihilation

- The total intensity  $I(T)$  radiated from a blackbody (at all wavelengths  $\lambda$ ) is equal to the integral over all wavelengths.  $0 < \lambda < \infty$ , of the Planck distribution  $I(\lambda, T) = \frac{2\pi hc^2}{\lambda^5 (e^{hc/\lambda k_B T} - 1)}$ . (a) By changing variables to  $x = hc/\lambda k_B T$ , show that  $I(T)$  has the form  $I(T) = \sigma T^4$ , where  $\sigma$  is a constant independent of temperature. This result is called **Stefan's fourth-power law**, after the Austrian physicist Josef Stefan. (b) Given that  $\int_0^\infty \frac{x^3 dx}{e^x - 1} = \pi^4 / 15$ , show that the Stefan-Boltzmann Constant  $\sigma$  is  $\sigma = \frac{2\pi^5 k^4}{15h^3 c^2}$ . (c) Evaluate  $\sigma$  numerically, and find the total power radiated from a red-hot ( $T = 1000$  K) steel ball of radius 1 cm. (Such a ball is well approximated as a blackbody.) (Taylor, Problem 4.4, pg. 141.) **ANS: (c) 71 W**
- If Planck constant were smaller than it is, would quantum phenomena be more or less conspicuous than they are now? (Beiser, Ex. 1, pg. 89)
- The diameter of an atomic nucleus is about  $10 \times 10^{-15}$  m. Suppose you wanted to study the diffraction of photons by nuclei. What energy of photons would you choose? (Krane, Q.1, pg. 94)
- Electric current is charge flowing per unit time. If we increase the kinetic energy of the electron by increasing the energy of the photons, shouldn't the current increase, because the charge flows more rapidly? Why doesn't it? (Krane, Q.6, pg. 94)
- What would be the effects on a photoelectric effect if we were to double the frequency of the incident light? If we were to double the wavelength? If we were to double the intensity? (Krane, Q.7, pg. 94)
- The Compton-scattering formula suggests that objects viewed from different angles should reflect light of different wavelengths. Why don't we observe a change in colour of objects as we change the viewing angle? (Krane, Q.16, pg. 95)
- You have a monoenergetic source of X-rays of energy 84 keV, but for an experiment you need 70 keV X-rays. How would you convert the X-ray energy from 84 to 70 keV? (Krane, Q.16, pg. 95)
- Show that a photon cannot transfer all of its energy to a free electron. (*Hint*: Note that energy and linear momentum must be conserved.) (Serway, Moses and Moyer, P27. pg. 103)
- The determination of Avogadro's number with x-rays.** X-rays from a molybdenum ( $0.626$  Å) are incident on a NaCl crystal, which has the atomic arrangement shown in Figure below. If NaCl has a density of  $2.17$  g/cm<sup>3</sup> and the  $n=1$  diffraction maximum from planes separated by  $d$  is found at  $\theta = 6.41^\circ$ , compute Avogadro's number. (*Hint*: First determine  $d$ . Using Figure P3.39, determine the number of NaCl molecules per primitive cell and set the mass per unit volume of the primitive cell equal to the density. (Serway, Moses and Moyer, P39, pg./ 104)

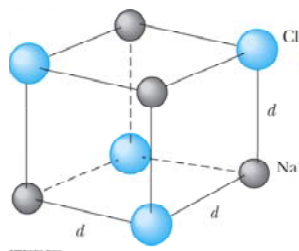

**ANS:**  $N_A = 6.13 \times 10^{23}$  /mole

- Two light sources are used in a photoelectric experiment to determine the work function for a particular metal surface. When green light from a mercury lamp ( $\lambda = 546.1$  nm) is used, a retarding potential of  $1.70$  V reduces the photocurrent to zero. (a) Based on this measurement, what is the work function for this metal? (b) What

stopping potential would be observed when using the yellow light from a helium discharge tube ( $\lambda = 587.5$  nm)? (Serway, Moses and Moyer. P42, pg 104)

**ANS: (a) 0.571 eV; (b) 1.54 V**

11. Monochromatic X rays are incident on a crystal in the geometry of Figure below.

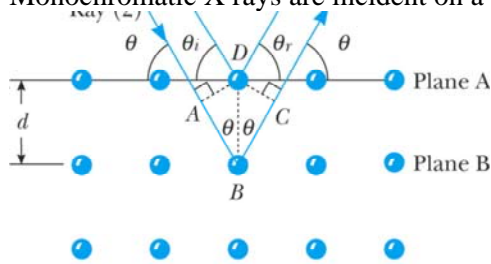

The first-order Bragg peak is observed when the angle of incidence is  $34.0^\circ$ . The crystal spacing is known to be  $0.347$  nm. (a) What is the wavelength of the X rays? (b) Now consider a set of crystal planes that makes an angle of  $45^\circ$  with the surface of the crystal (as in the Figure). For X rays of the same wavelength, find the angle of incidence measured from the surface of the crystal that produces the first-order Bragg peak. At what angle from the surface does the emerging beam appear in this case? (Krane, P3, pg 95)

12. The universe is filled with thermal radiation, which has a bla at an effective temperature of  $2.7$  K. What is the peak wavelength of this radiation? What is the energy (in eV) of a quanta at the peak wavelength? In what region of the electromagnetic spectrum is this peak wavelength? (Krane. P 20, pg 96)
13. Light from the sun arrives at the earth an average of  $1.5 \times 10^{11}$  m away, at the rate of  $1.4 \times 10^{13}$  W/m of area perpendicular to the direction of the light. Assume that sunlight is monochromatic with a frequency of  $5 \times 10^{14}$  Hz. (a) How many photons fall per second on each square meter of Earth's surface directly facing the sun? (b) What is the power output of the sun, and how many photons per second does it emit? (c) How many photons per cubic meter are there near the earth? (Beiser, Ex. 9, pg. 90)

**ANS: (a)  $4.2 \times 10^{21}$ ; (b)  $4.2 \times 10^{26}$  Watt;  $1.2 \times 10^{45}$  photon per second (c)  $1.4 \times 10^{13}$  photon/m<sup>3</sup>**

14.  $1.5$  mW of  $400$ -nm light is directed at a photoelectric cell. If  $0.10$  percent of the incident photons produce photoelectrons, find the current in the cell. (Beiser, Ex. 15, pg. 90)

**ANS:  $0.48 \mu\text{A}$**

15. (a) Find the change in wavelength of  $80$ -pm x-rays that are scattered  $120^\circ$  by a target, (b) Find the angle between the directions of the recoil electron and the incident photon. (c) Find the energy of the recoil electron. (Beiser, Ex. 34, pg. 90)

**ANS: (a)  $3.64$  pm (b)  $29.3^\circ$  (c)  $674$  eV**

16. A photon of frequency  $\nu$  is scattered by an electron initially at rest. Verify that the maximum kinetic energy of the recoil electron is  $KE_{\text{max}} = (2h^2\nu^2/mc^2) / (1 + 2h\nu/mc^2)$  (Beiser, Ex. 35, pg. 90)

17. Show that, regardless of its initial energy, a photon cannot undergo Compton scattering through an angle of more than  $60^\circ$  and still be able to produce an electron-positron pair. (Hint: Start by expressing the Compton wavelength of the electron in terms of the maximum photon wavelength needed for pair production.) (Beiser, Ex. 41, pg. 91)

18. (a) Verily that the minimum energy a photon must have to create an electron-positron pair in the presence of a stationary nucleus of mass  $M$  is  $2mc^2/(1 + m/M)$ , where  $m$  is the electron rest mass. (b) Find the minimum energy needed for pair production in the presence of a proton. (Beiser, Ex. 42, pg. 91)

**ANS: (b)  $1.023$  MeV**

19. Why is it in a pair annihilation the resultant photons cannot be singly produced?

### TUTORIAL 3

#### Wave properties of particles

- Suppose we cover one slit in the two-slit experiment with a very thin sheet of fluorescent material that emits a photon of light whenever an electron passes through. We then fire electrons one at a time at the double slit; whether or not we see a flash of light tells us which slit the electron went through. What effect does this have on the interference pattern? Why? (*Suggestion: Read Chap. 1, Feynman Lectures on Physics Vol. 3*) (Krane, Q13, pg. 131.)
- The speed of an electron is measured to within an uncertainty of  $2.0 \times 10^4$  m/s. What is the size of the smallest region of space in which the electron can be confined? (Krane, P14, pg. 133)

- A pi meson (pion) and a proton can briefly join together to form a  $\Delta$  particle. A measurement of the energy of the  $\pi p$  system (see Figure) shows a peak at 1236 MeV, corresponding to the rest energy of the  $\Delta$  particle, with an experimental spread of 120 MeV. What is the lifetime of the  $\Delta$ ? (Krane, P17, pg. 133)

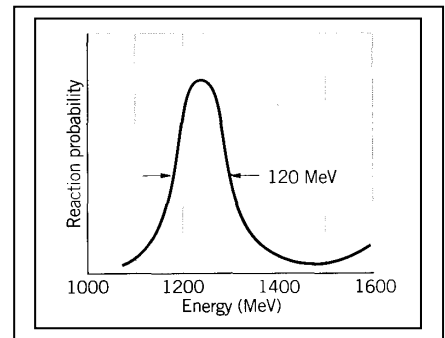

- A proton or a neutron can sometimes “violate” conservation of energy emitting and then reabsorbing a pi meson, which has a mass of  $135 \text{ MeV}/c^2$ . This is possible as long as the pi meson is reabsorbed within a short enough time  $\Delta t$  consistent with the uncertainty principle. (a) Consider  $p \rightarrow p + \pi$ . By what amount  $\Delta E$  is energy conservation violated? (ignore any kinetic energies.) (b) For how long a time  $\Delta t$  can the pi meson exist? (c) Assuming pi meson to travel at very nearly the speed of light, how far from the proton can it go? (This procedure gives us an estimate of the range of the nuclear force, because we believe that protons and neutron are held together in the nucleus by exchanging pi mesons.) (Krane, P22, pg. 133)

- Show that the formula for low-energy electron diffraction (LEED), when electrons are incident perpendicular to a crystal surface, may be written as  $\sin \phi = \frac{nhc}{d(2m_e c^2 K)^{1/2}}$ , where  $n$  is the order of the maximum,  $d$

is the atomic spacing,  $m_e$  is the electron mass,  $K$  is the electron's kinetic energy, and  $\phi$  is the angle between the incident and diffracted beams, (b) Calculate the atomic spacing in a crystal that has consecutive diffraction maxima at  $\phi = 24.1^\circ$  and  $\phi = 54.9^\circ$  for 100-eV electrons. (Serway, M & M, P 14,

pg. 188) **ANS:**  $33 \times 10^{-10}$  m for  $n=1$ ,  $33 \times 10^{-10}$  m for  $n=2$ )

- A woman on a ladder drops small pellets toward a spot on the floor, (a) Show that, according to the uncertainty principle, the miss distance must be at least  $\Delta x = \left(\frac{\hbar}{2m}\right)^{1/2} \left(\frac{H}{2g}\right)^{1/4}$ , where  $H$  is the initial height of each pellet above the floor and  $m$  is the mass of each pellet, (b) If  $H = 2.0$  m and  $m = 0.50$  g, what is  $\Delta x$ ? (Serway & M & M, P 21, pg. 188) **ANS:** (b)  $\Delta x_{\text{total}} = 5.2 \times 10^{-16}$  m

- An excited nucleus with a lifetime of 0.100 ns emits a  $\gamma$  ray of energy 2.00 MeV. Can the energy width (uncertainty in energy,  $\Delta E$ ) of this 2.00-MeV  $\gamma$  emission line be directly measured if the best gamma detectors can measure energies to  $\pm 5$  eV? (Serway & M & M, P 25, pg. 188)

**ANS:** NO

8. Find the de Broglie wavelength of a 1.00-MeV proton. Is a relativistic calculation needed? (Beiser, Ex. 6, pg. 117) **ANS:**  $2.86 \times 10^{-14}$  m; No need.

9. Show that the de Broglie wavelength of a particle of mass  $m$  and kinetic energy KE is given by

$$\lambda = \frac{hc}{\sqrt{KE(KE + 2mc^2)}} \quad (\text{Beiser, Ex. 10, pg. 117})$$

10. What effect on the scattering angle in the Davisson-Germer experiment does increasing the electron energy have? (Beiser, Ex. 23, pg. 117)

11. A beam of 50-keV electrons is directed at a crystal and diffracted electrons are found at an angle of  $50^\circ$  relative to the original beam. What is the spacing of the atomic planes of the crystal? A relativistic calculation is needed for  $\lambda$ . (Beiser, Ex. 26, pg. 117) **ANS:** 3.0 pm

12. The lowest energy possible for a certain particle trapped in a certain box is 1.00 eV. (a) What are the next two higher energies the particle can have? (b) If the particle is an electron, how wide is the box? (Beiser, Ex. 29, pg. 118)

**ANS:** (a) 4 eV, 9 eV; (b) 45 fm

13. Discuss the prohibition of  $E = 0$  for a particle trapped in a box  $L$  wide in terms of the uncertainty principle. How does the minimum momentum of such a particle compare with the momentum uncertainty required by the uncertainty principle if we take  $\Delta x = L$ ? (Beiser, Ex. 30, pg. 118)

14. (a) How much time is needed to measure the kinetic energy of an electron whose speed is 10.0 m/s with an uncertainty of no more than 0.100 percent? How far will the electron have travelled in this period of time? (b) Make the same calculations for a 1.00-g insect whose speed is the same. What do these sets of figures indicate? (Beiser, Ex. 34, pg. 118)

**ANS:** (a) 1.2 ms, 1.2 cm; (b)  $9.5 \times 10^{-29}$  s,  $9.5 \times 10^{-28}$  m.

15. How accurately can the position of a proton with  $v \ll c$ . be determined without giving it more than 1.00 keV of kinetic energy? (Beiser, Ex. 35, pg. 118). **ANS:** 0.144 pm

16. (a) Find the magnitude of the momentum of a particle in a box in its  $n$ th state. (b) The minimum change in the particles momentum that a measurement can cause corresponds to a change of  $\pm 1$  in the quantum number  $n$ . If  $\Delta x = L$ . show that  $\Delta p \Delta x \geq \hbar / 2$ . (Beiser, Ex. 36, pg. 118)

**ANS:** (a)  $nh/2L$ ; (b)  $h/2L$ ;

## TUTORIAL 4

### Atomic models

1. How is the quantization of the energy in the hydrogen atom similar to the quantization of the systems discussed in the 1-D infinite quantum well? How is it different? Do the quantizations originate from similar causes? (Krane, Q8, pg. 201)
2. In both the Rutherford theory and the Bohr theory, we used the classical expression for the kinetic energy. Estimate the velocity of an electron in the Bohr atom and of an alpha particle in a typical scattering experiment, and decide if the use of the classical formula is justified. (Krane, Q14, pg. 201)
3. The lifetimes of the levels in a hydrogen atom are of the order of  $10^{-8}$  s. Find the energy uncertainty of the first excited state and compare it with the energy of the state. (Krane, P29, pg. 204)
4. A long time ago, in a galaxy far, far away, electric charge had not yet been invented, and atoms were held together by gravitational forces. Compute the Bohr radius and the  $n=2$  to  $n=1$  transition energy in a gravitationally bound hydrogen atom. (Krane, P33, pg. 204)
5. The **fine structure constant** is defined as  $\alpha = e^2/2\epsilon_0hc$ . This quantity got its name because it first appeared in a theory by the German physicist Arnold Sommerfeld that tried to explain the line structure in spectral lines (multiple lines close together instead of single lines) by assuming that elliptical as well as circular orbits are possible in the Bohr model. Sommerfeld's approach was on the wrong track, but  $\alpha$  has nevertheless turned out to be a useful quantity in atomic physics, (a) Show that  $\alpha = v_1/c$ , where  $v_1$  is the velocity of the electron in the ground state of the Bohr atom, (b) Show that the value of  $\alpha$  is very close to  $1/137$  and is a pure number with no dimensions. Because the magnetic behavior of a moving charge depends on its velocity, the small value of  $\alpha$  is representative of the relative magnitudes of the magnetic and electric aspects of electron behavior in an atom (c) Show that  $\alpha a_0 = \lambda_c / 2\pi$ , where  $a_0$  is the radius of the ground-state Bohr orbit and  $\lambda_c$  is the Compton wavelength of the electron. (Beiser Ex. 9, pg. 158)
6. Show that the energy of the photon emitted when a hydrogen atom makes a transition from state  $n$  to state  $n-1$  is, when  $n$  is very large,  $\Delta E \cong \alpha^2(mc^2/n^3)$  where  $\alpha$  is the fine structure constant. (Krane, P38, pg. 205)
7. Can the electron in the ground state of the hydrogen atom absorb a photon of energy (a) less than 13.6 eV and (b) greater than 13.6 eV? (c) What is the minimum photon energy that can be absorbed by the ground state of the hydrogen atom? (Serway, M & M, Q3, pg. 145)  
**ANS:** (a) Yes (b) No (c) 10.2 eV
8. Four possible transitions for a hydrogen atom are listed here.  
 (A)  $n_i = 2; n_f = 5$       (B)  $n_i = 5; n_f = 3$       (C)  $n_i = 7; n_f = 4$       (D)  $n_i = 4; n_f = 7$   
 (a) Which transition emits the photons having the shortest wavelength?  
 (b) For which transition does the atom gain the most energy? (c) For which transition(s) does the atom lose energy? (Serway, M & M. Q11, pg. 145)

9. An electron initially in the  $n = 3$  state of a one-electron atom of mass  $M$  at rest undergoes a transition to the  $n = 1$  ground state. (a) Show that the recoil speed of the atom from emission of a photon is given approximately by  $v = 8hR/9M$ . (b) Calculate the percent of the  $3 \rightarrow 1$  transition energy that is carried off by the recoiling atom if the atom is deuterium. (Serway, M & M. Q29, pg. 148)

**ANS:** (b)  $3.23 \times 10^{-8} \%$

10. *The Auger process.* An electron in chromium makes a transition from the  $n = 2$  state to the  $n = 1$  state without emitting a photon. Instead, the excess energy is transferred to an outer electron (in the  $n = 4$  state), which is ejected by the atom. (This is called an Auger process, and the ejected electron is referred to as an Auger electron.) Use the Bohr theory to find the kinetic energy of the Auger electron. (Serway, M & M. Q28, pg. 148)

**ANS:** 5.385 keV

11. In a hot star, a multiply ionized atom with a single remaining electron produces a series of spectral lines as described by the Bohr model. The series corresponds to electronic transitions that terminate in the same final state. The longest and shortest wavelengths of the series are 63.3 nm and 22.8 nm, respectively. (a) What is the ion? (b) Find the wavelengths of the next three spectral lines nearest to the line of longest wavelength. (Serway, M & M. Q44, pg. 150) **ANS:** (a)  $O^{7+}$ ; (b) 41.0 nm, 33.8 nm, 30.4 nm

12. Find the frequency of revolution of the electron in the classical model of the hydrogen atom. In what region of the spectrum are electromagnetic waves of this frequency? (Beiser, Ex. 4, pg. 157) **ANS:**  $6.6 \times 10^{15}$  Hz, ultraviolet

13. What is the shortest wavelength present in the Bracken series of spectral lines? (Beiser, Ex.5, pg. 158)

**ANS:** 1459 nm

14. A beam of 13.0-eV electrons is used to bombard gaseous hydrogen. What series of wavelengths will be emitted? (Beiser Ex. 16, pg. 158). **ANS:** Excited to the  $n = 4$  level but no higher

15. The longest wavelength in the Lyman series is 121.5 nm and the shortest wavelength in the Balmer series is 364.6 nm. Use the figures to find the longest wavelength of light that could ionize hydrogen. (Beiser, Ex. 23, pg. 158) **ANS:** 91.13 cm

16. When an excited atom emits a photon, the linear momentum of the photon must be balanced by the recoil momentum of the atom. As a result, some of the excitation energy of the atom goes into the kinetic energy of its recoil. (a) Modify  $E_i - E_f = h\nu$  to include this effect, (b) Find the ratio between the recoil energy and the photon energy for the  $n = 3 \rightarrow n \rightarrow 2$  transition in hydrogen, for which  $E_f - E_i = 1.9$  eV. Is the effect a major one? A nonrelativistic calculation is sufficient here. (Beiser, Ex. 27, pg. 158)

**ANS:** (a) 
$$E_f - E_i = h\nu \left( 1 + \frac{1}{2} \left( 1 + \frac{Mc^2}{h\nu} \right) \right)$$

(b)  $1.0 \times 10^{-9}$ ; nonrelativistic is sufficient

## TUTORIAL 5

### Introductory Quantum Mechanics

1. Which of the following wave functions cannot be solutions of Schrodinger's equation for all values of  $x$ ? Why not? (a)  $\psi = A \sec x$ ; (b)  $\psi = A \tan x$ ; (c)  $\psi = A e^{x^2}$ ; (d)  $\psi = A e^{-x^2}$  (Beiser, Ex. 3, pg. 197)  
**ANS:** only (d) could be a solution
2. The wave function of a certain particle is  $\psi = A \cos^2 x$  for  $\pi/2 < x < \pi/2$ . (a) Find the value of  $A$ . (b) Find the probability that the particle be found between  $x = 0$  and  $x = \pi/4$  (Beiser, Ex. 5, pg. 197)  
**ANS:** (a)  $\sqrt{\frac{8}{3}}$ ; (b) 0.462
3. The expectation value  $\langle x \rangle$  of a particle trapped in a box  $a$  wide is  $a/2$  ( $0 \leq x \leq a$ ), which means that its average position is the middle of the box. Find the expectation value  $\langle x^2 \rangle_n$  in the stationary state  $n$ . What is the behaviour of  $\langle x^2 \rangle_n$  as  $n$  becomes infinity. Is this consistent with classical physics? (Beiser, Ex. 17, pg. 198). **ANS:**  $a^2 \left( \frac{1}{3} - \frac{1}{2\pi^2 n^2} \right)$ .
4. Find the probability that a particle in a box  $L$  wide can be found between  $x = 0$  and  $x = L/n$  when it is in the  $n$ th state. (Beiser, Ex. 19, pg. 198)  
**ANS:**  $1/n$ .
5. What is the physical meaning of  $\int_{-\infty}^{\infty} |\psi|^2 dx = 1$   $\psi dx = 1$ ? (Krane, Q3, pg/ 168)
6. What are the dimensions of  $\psi(x)$ ? (Krane, Q4, pg. 168)  
**ANS:**  $\sqrt{L}$ .
7. What happens to the probability density in the infinite well when  $n \rightarrow \infty$ ? Is this consistent with classical physics? (Krane, Q6, pg. 168)
8. How would the solution to the one-dimensional infinite potential energy well be different if the potential energy were not zero for  $0 \leq x \leq L$  but instead had a constant value  $U_0$ . What would be the energies of the excited states? What would be the wavelengths of the standing de Broglie waves? Sketch the behavior of the lowest two wave functions. (Krane, Q6, pg. 168)
9. A particle in an infinite well is in the ground state with an energy of 1.26 eV. How much energy must be added to the particle to reach the second excited state ( $n = 3$ )? The third excited state ( $n = 4$ )? (Krane, P4, pg. 170)
10. An electron is trapped in a one-dimensional well of width 0.132 nm. The electron is in the  $n = 10$  state. (a) What is the energy of the electron? (b) What is the uncertainty in its momentum? (c) What is the uncertainty in its position? How do these results change as  $n \rightarrow \infty$ ? Is this consistent with classical behavior? (Krane, P9, pg. 170)
11. Consider a particle moving in a one-dimensional box with walls at  $x = -L/2$  and  $x = +L/2$ . (a) Write the wave functions and probability densities for the states  $n = 1$ ,  $n = 2$ , and  $n = 3$ . (b) Sketch the wave function and probability densities. (Hint: Make an analogy to the case of a particle in a box with walls at  $x = 0$  and  $x = L$ ) (Serway, M & M, P11, pg. 228)



12. A particle of mass  $m$  is placed in a one-dimensional box of length  $L$ . The box is so small that the particle's motion is relativistic, so that  $E = p^2/2m$  is not valid. (a) Derive an expression for the energy levels of the particle using the relativistic energy- momentum relation and the quantization of momentum that derives from confinement. (b) If the particle is an electron in a box of length  $L = 1.00 \times 10^{-12} \text{m}$ , find its lowest possible kinetic energy. By what percent is the nonrelativistic formula for the energy in error? (Serway, M & M, P14, pg. 228)

**ANS:** (a)  $K_n = \left[ \left( \frac{nhc}{2L} \right)^2 + (mc^2)^2 \right]^{1/2} - mc^2$ ; (b) 0.29 MeV, 29% too big